



# LaCoste & Romberg

*The first name in gravity since 1939*

## Air-Sea Gravity System II™

### A New Generation Dynamic Gravity Meter

In 1965 LaCoste & Romberg, manufacturers of high-precision gravity meters since 1939, introduced the world's first dynamically stabilized platform gravity meter. These meters revolutionized the geophysics world by making it possible, for the first time, to take highly accurate gravity measurements from a moving ship or aircraft. Since then, over a hundred of these instruments have sailed or flown around the world, logging millions of hours of gravity data.

LaCoste & Romberg is proud to introduce our next-generation successor to the renowned S-Meter system: **The L&R Air-Sea Gravity System II.** Based on our famous, time-tested Zero-Length Spring™ sensor technology, the System II incorporates an advanced electronics system, user-friendly software, and a more compact, self contained sensor platform.

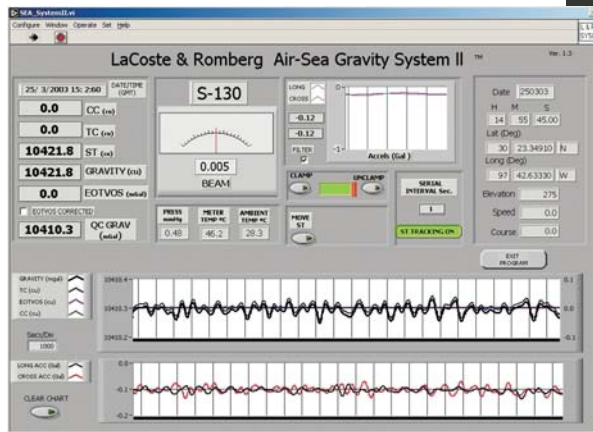
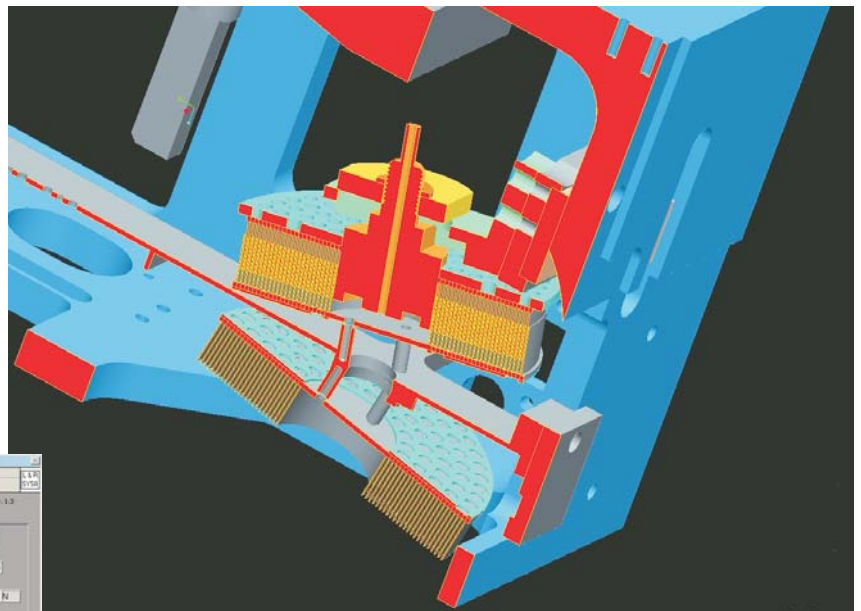

The Air-Sea Gravity System II offers capabilities unmatched by any stable-platform system currently in service. Fiber-Optic gyros, state of the art accelerometers, a tightly-integrated digital control system and modern digital filters offer increased precision and greater reliability, even while running unattended.

### Control System Features

- Microsoft Windows™ interface
- Simple configuration
- Separate Air and Sea Versions
- Real Time Data Output to Serial Port and Internal Hard drive at 1hz
  - Data Output spreadsheet compatible
- GPS input
- User selectable FIR low-pass digital filtering.
- Real Time EOTVOS corrections on Sea Version
- Real Time graphic plots with user-selectable time bases.
- Self diagnostics at start-up with logged report.

- ✓ **Gyros** - The Air-Sea System II has solid-state Fiber-Optic Gyros (FOGs). The highest sensitivity is possible using direct digital output. The system is also compatible with new mechanical gyros.
- ✓ **Digital Control System** - The all-new digital control system stabilizes the platform and sensor, records data, and monitors system performance with greater reliability.
- ✓ **DSP Platform Control** - A digital processor board keeps the platform level independently of the system computer. This control system allows higher platform gain which gives faster response times and smaller errors.
- ✓ **Repeatability** - Laboratory tests show a dynamic repeatability of better than 0.25 mGals.
- ✓ **Increased Precision** - Internal sampling of the analog signals at 1000 Hz improves accuracy, avoids aliasing, and produces 21 Bit effective resolution.
- ✓ **Reliability** - The new Air-Sea Gravity System II employs industrial-grade electronics designed for long life and high reliability even in adverse conditions, minimizing the need for operator intervention and maintenance. Built-in diagnostic functions assist the operator in troubleshooting and repairs when necessary. Spare electronics are full modular plug-ins for less downtime
- ✓ **Uninterruptible Power Supply** - An Uninterruptible Power Supply is standard on the system, insulating the system from power fluctuations. It accepts AC input voltage (80-265 VAC).
- ✓ **Spring Tension Absolute Encoder** - Spring Tension value is stored in permanent memory.
- ✓ **Stable Time Base** - Rubidium oscillator provides precision sampling.
- ✓ **GPS Interface** - GPS data is recorded and a real-time EÖTVÖS correction is calculated.
- ✓ **Upgrade Your Meter!** - Upgrades are available for all older L&R Air-Sea Gravity Meters



## Specifications

### System Performance

**Resolution:** 0.01 mGal

**Static Repeatability:** 0.05 mGal

**Dynamic Repeatability:**

50,000 mGal Horz. Acceleration: 0.25 mGal

100,000 mGal Horz. Acceleration: 0.50 mGal

100,000 mGal Vert. Acceleration: 0.25 mGal

**Accuracy at Sea:** <1.00 mGal reported

**Platform Range:** 25° of roll and 22° pitch

**Platform Period:** 4 Minutes - user adjustable

**Platform Damping:** 0.707 of critical damping

**Drift:** <3.0 mGal per month after aging

**Range:** 12,000 mGals (Worldwide)

**Size** - 71 x 56 x 84 cm; 28.0 x 22.0 x 33 in.

**Weight** - 86 kg; 190 lbs. UPS: 30 kg; 65 lbs.

**Power** - 240 watts avg., 450 watts max., 80-265 VAC, 47-63 Hz

**Warranty** - Two-year warranty on parts and labor

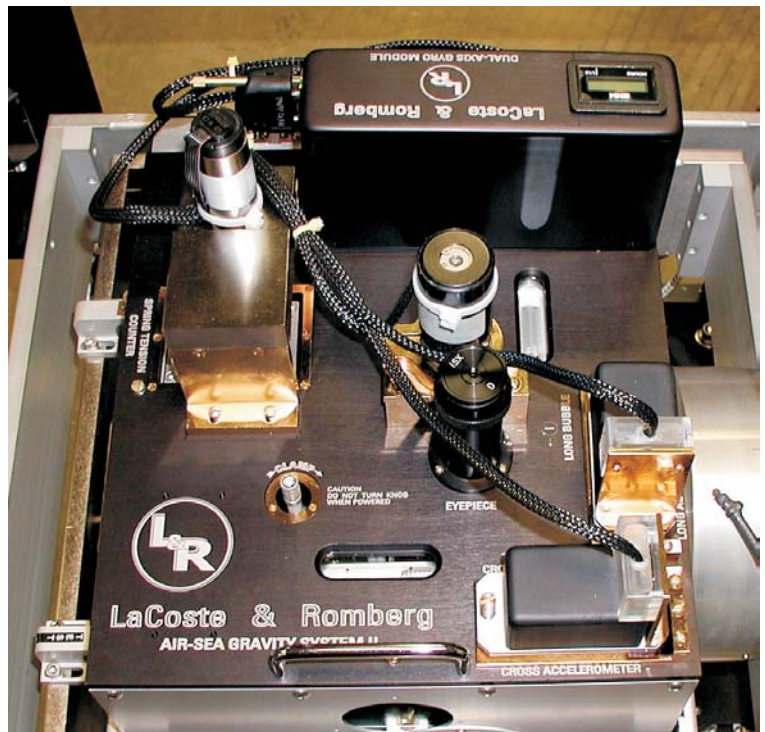

## LaCoste & Romberg

11002 Metric Blvd, Ste 100

Austin, TX 78758, USA

Tel: (512) 346-0077; Fax: (512) 346-0088

Http://www.LaCosteRomberg.com

Email: info@LaCosteRomberg.com